

<b>C1250 D2R</b>	<b>Continuous</b>		<b>Prime</b>		<b>Standby</b>	
	<b>kVA</b>	<b>kWe</b>	<b>kVA</b>	<b>kWe</b>	<b>kVA</b>	<b>kWe</b>
40 deg C	1005	804	1258	1005	1400	1120
45 deg C	1005	804	1258	1005	1400	1120
50 deg C	1005	804	1131	905	1260	1008
55 deg C	938	750	1025	820		

<b>C1250 D2R</b>	<b>Continuous</b>		<b>Prime</b>		<b>Standby</b>	
	<b>kVA</b>	<b>kWe</b>	<b>kVA</b>	<b>kWe</b>	<b>kVA</b>	<b>kWe</b>
40 deg C	1120	896	1400	1120	1588	1270
45 deg C	1120	896	1400	1120	1588	1270
50 deg C	1120	896	1288	1030	1425	1140
55 deg C	1063	850	1156	925		

- Standard ISO 20' container. CSC approved.
- Stackable.
- Durable finish. Sand blast, primer & top coat.
- 4 point lift, side ladder and fork lift slots.
- One large double access doors with air filter at the end of the compartment to service the engine and alternator.
- Lockable side doors with internal release.
- Acoustic louver with air inlet filter to prevent dust and sand ingress

- 110% internal bunding within the genset compartment, for greater environmental protection.
- Designed to meet the following noise level at free field condition :
  - 50 Hz: 80dBA @ 1m under 75% load,
  - 60 Hz: 80dBA @ 7m under 75% load,.
- Controller accessible from outside.
- Emergency stop button at both sides of the container.

# Value Package - Container



- Side doors access for ease of maintenance & serving.
- Insulated exhaust silencer mounted inside the container with rain cap.
- External topping points for fuel, oil & water.
- Metal flooring.

- PCC3100 with paralleling. Paralleling selector switch for Genset to Genset or Genset to utility paralleling.
- Key switch for PCC3100.
- Motorised 4 pole Circuit Breaker. Fixed Type
- External access to bus bar connection.
- Limit switch to shut down Genset when the door is open.

- Re-connectable Neutral/Earth link.
- Earth leakage protection.
- Dual frequency electric fan.
- Lighting 24v DC / 240VAC and 240V Socket Plug.
- Auxiliary supply, 220 – 240VAC.

- Manual oil drain pump.
- 900 litres fuel tank with external gauge.
  - Fuel filter with water separator.
  - External fuel connection (3-way valve)
- Battery Isolator
- Charging alternator.
- Added safety features for low coolant level shutdown, low fuel warning & shutdown. Fuel leakage warning.



- Automatic oil top up system with 50 litre lubricating oil tank.
- Electric fuel pump with external connection.
- Water jacket heater.
- Electric sump drain pump.
- AMF module with selector switch.
- Anti condensation heater
- Battery charger.

# Plan View

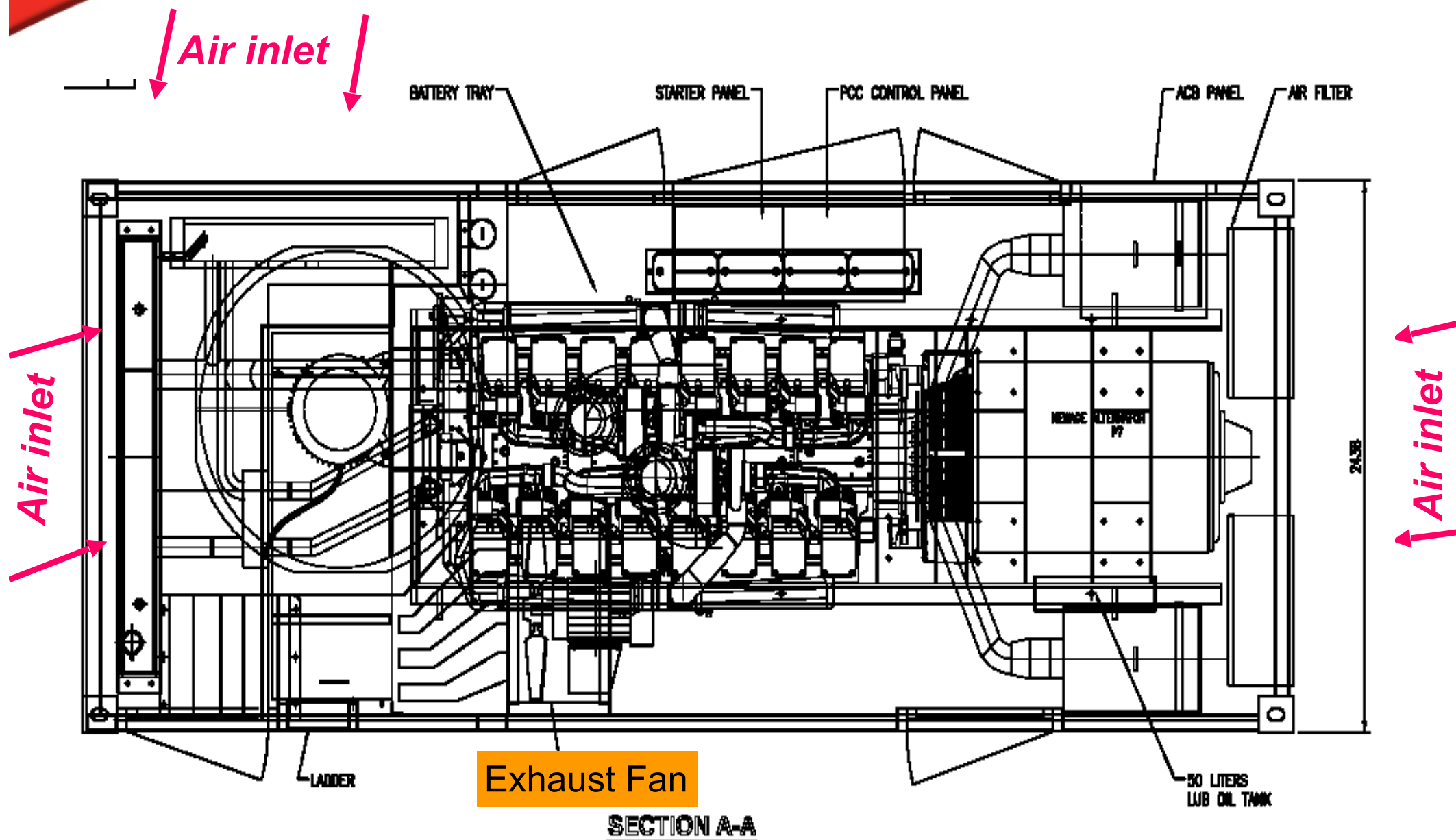

# Front View



Power Generation

Air Discharge Up

Exhaust outlet

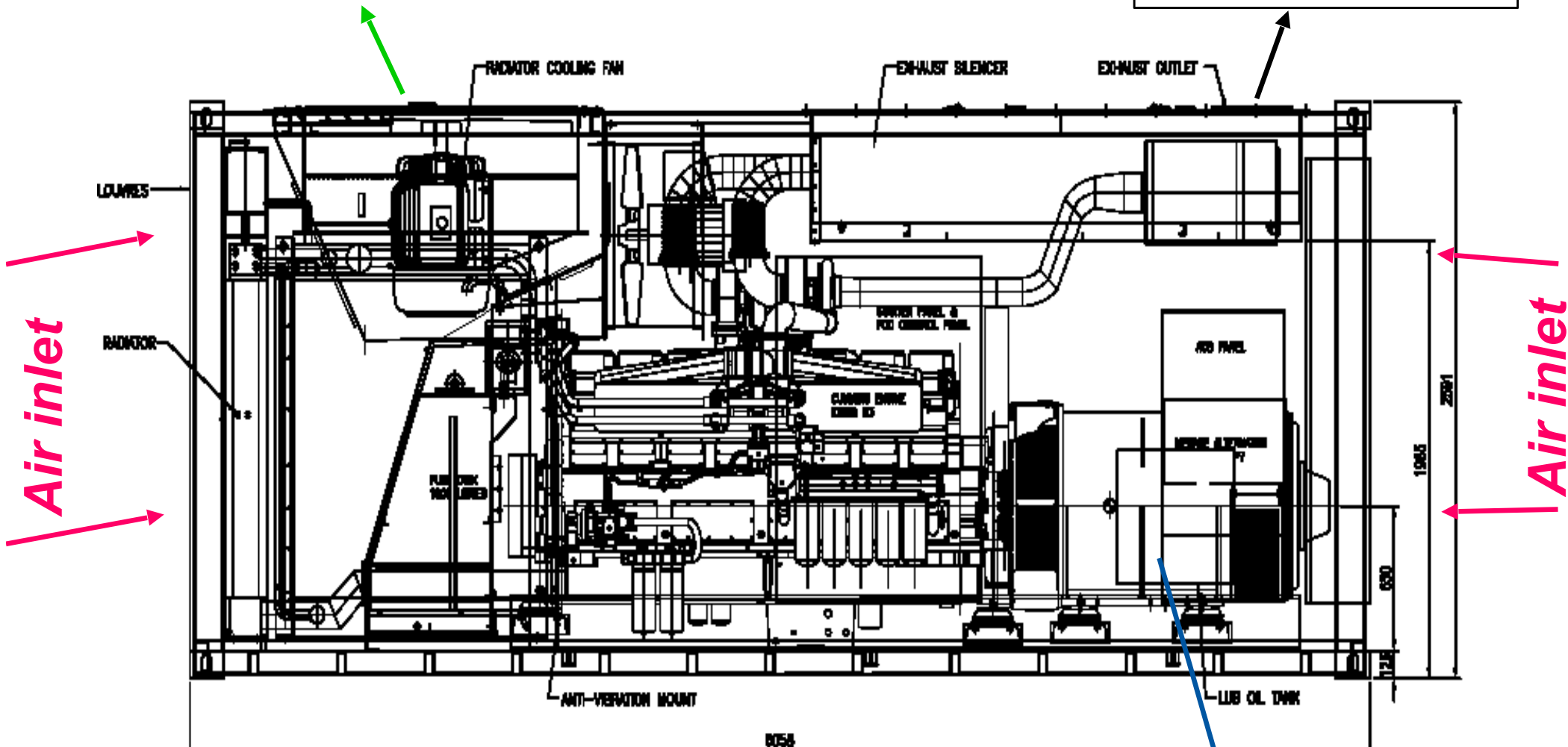

SECTION B-B

Lub oil tank

# Container – Connections & Filling Points



## Fuel Gauge & Refill Ports

## Emergency Stop

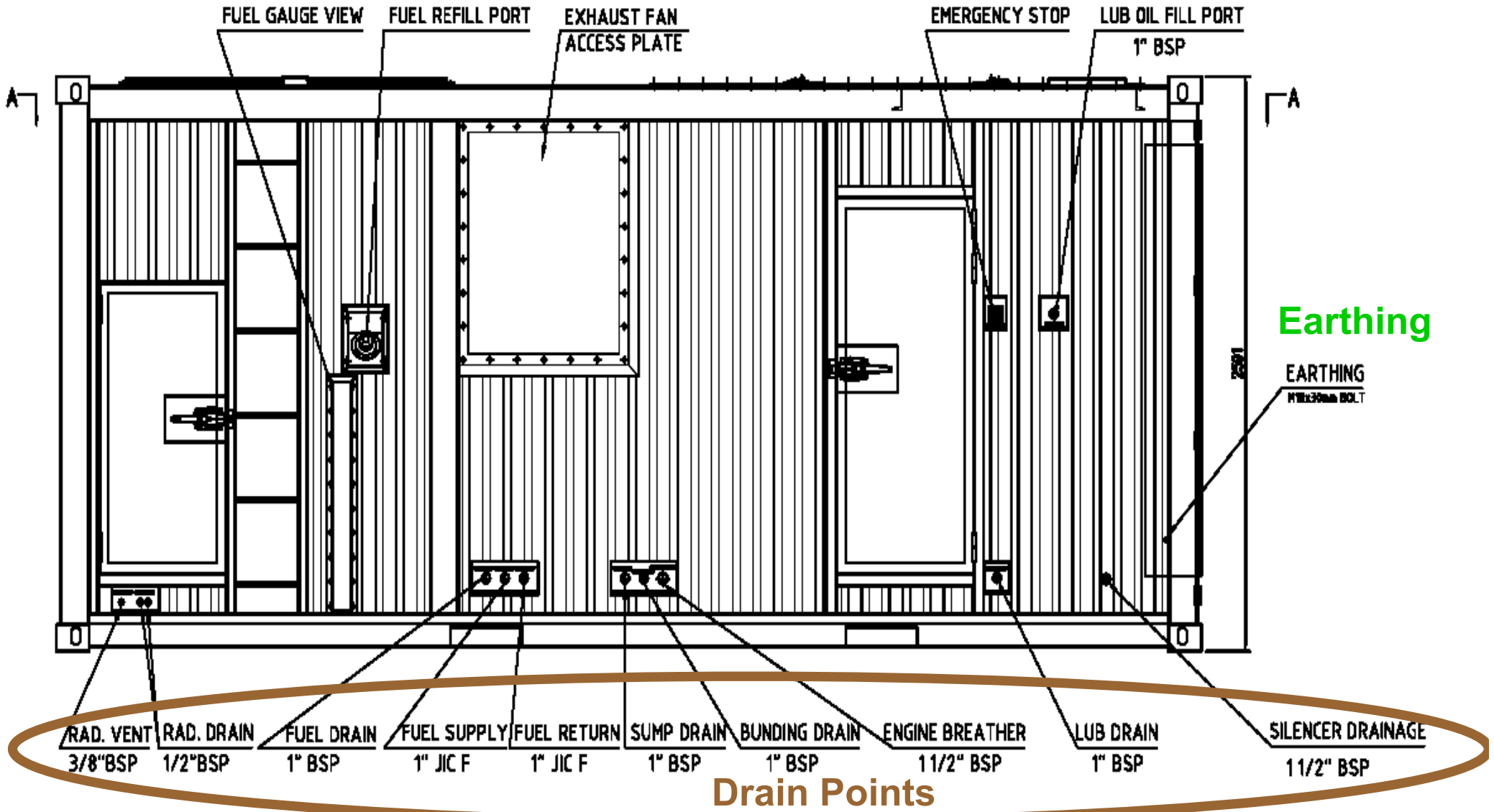

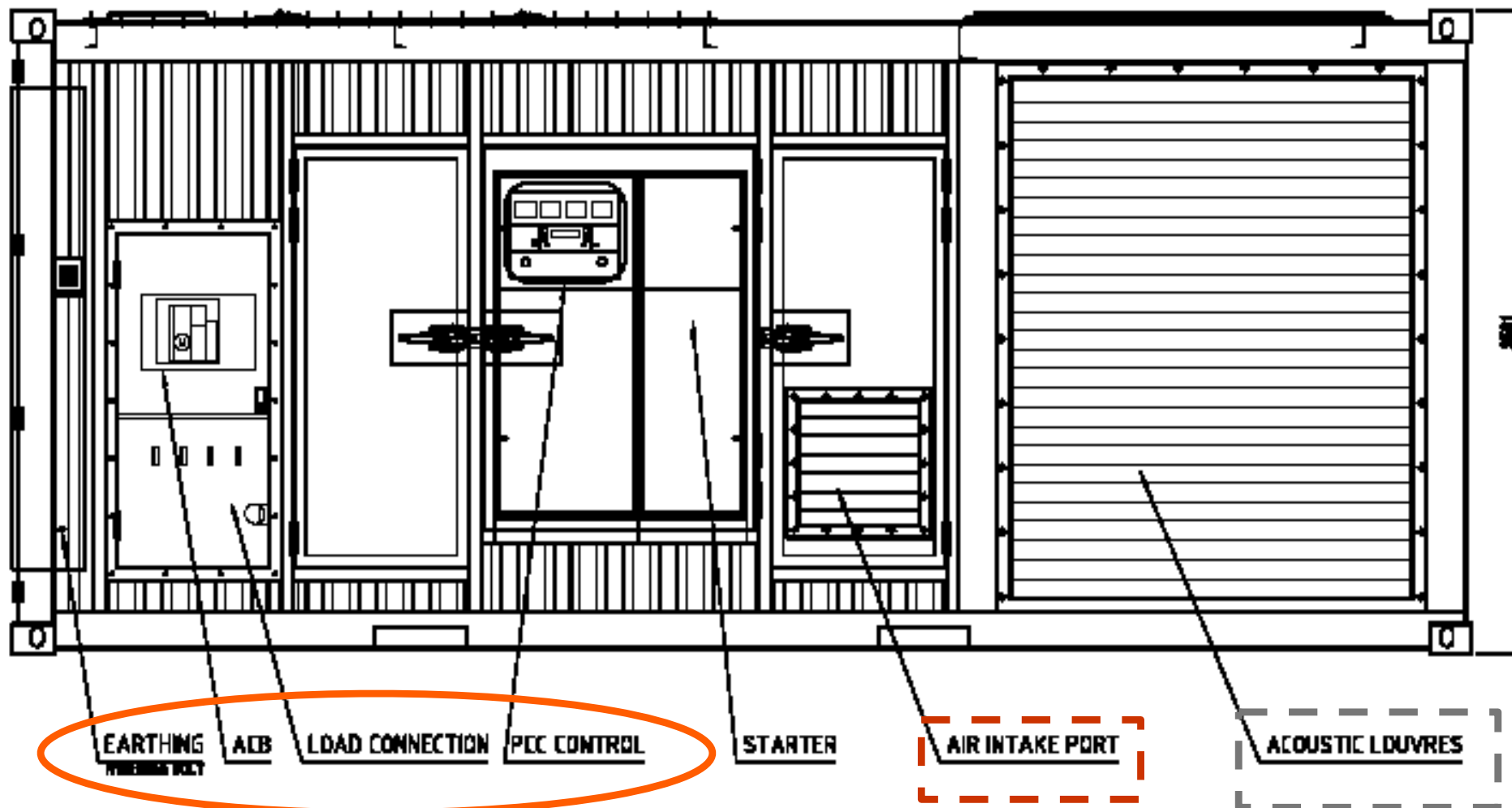

**External access to electrical connection**

**RIGHT SIDE VIEW**

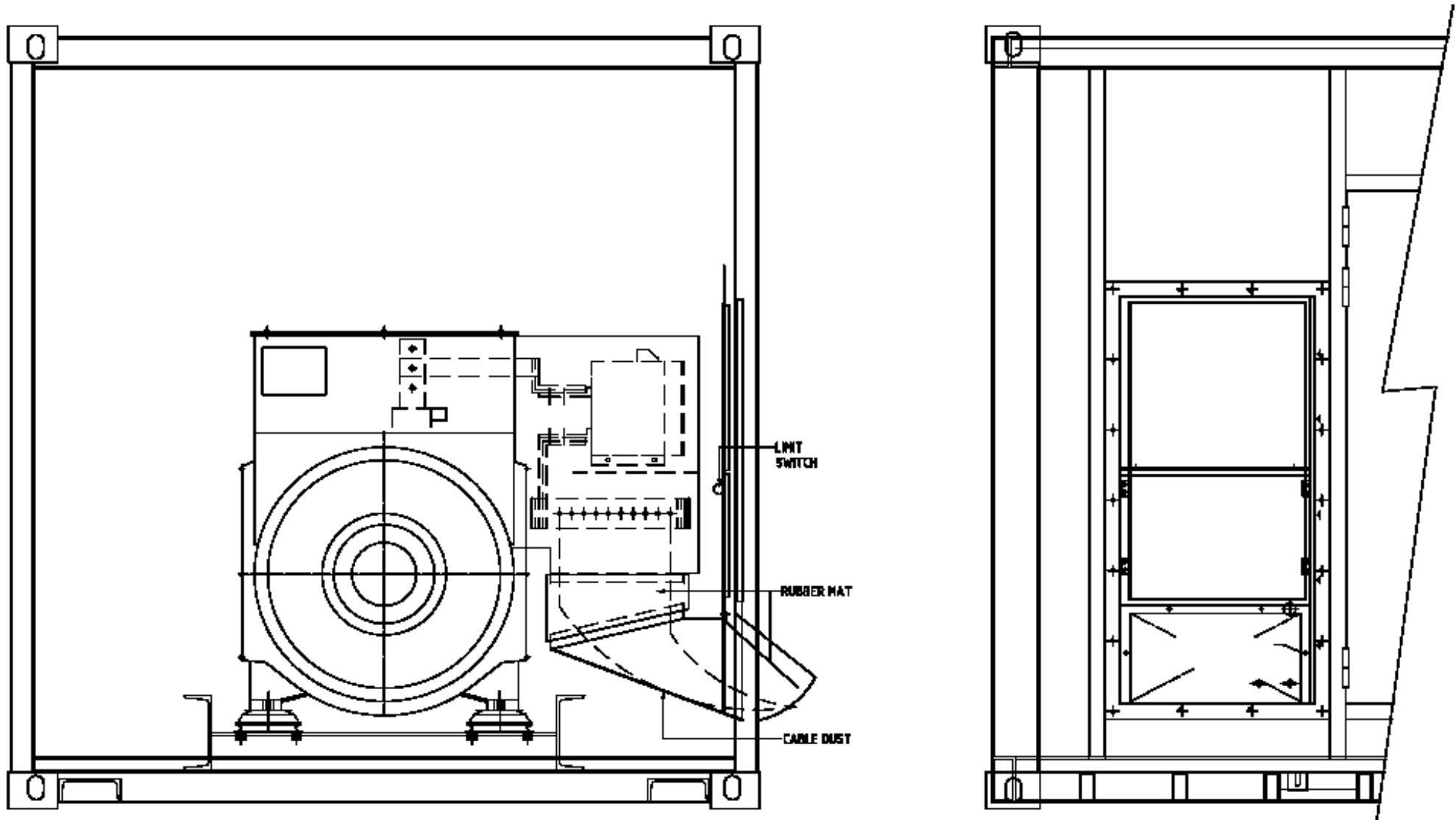

*Limit switch installed to shutdown GS when door is opened.*

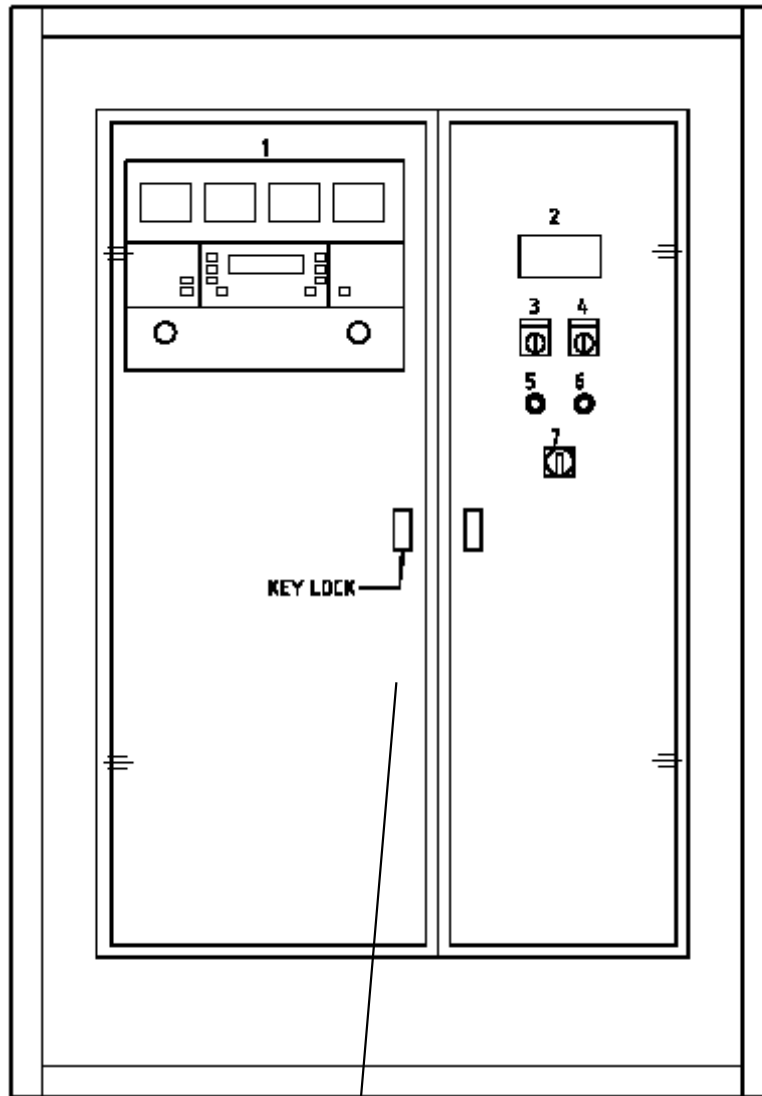

1. POWER COMMAND CONTROLLER (PARALLEL, PCCP3100)
2. 10 WAYS ANUNICATOR
3. EARTH LEAKAGE SWITCH, S10 (ENABLE-DISABLE)
4. PARALLEL MODE SWITCH, S11 (ISOLATED-PARA)
5. ILLUMINATED PUSHBUTTON ' MUTE ALARM' - YELLOW, S14
6. PUSHBUTTON 'FAULT RESET' - BLACK, S13
7. ALT/ENGINE/FAN HEATER SWITCH (ON-OFF)

**Key Lock**

# PowerBox 20X





# Side View



# Access for maintenance Drain P



**Drain points**

# Control Panel & Electrical connecti





***Filters to prevent dust and sand ingress***